

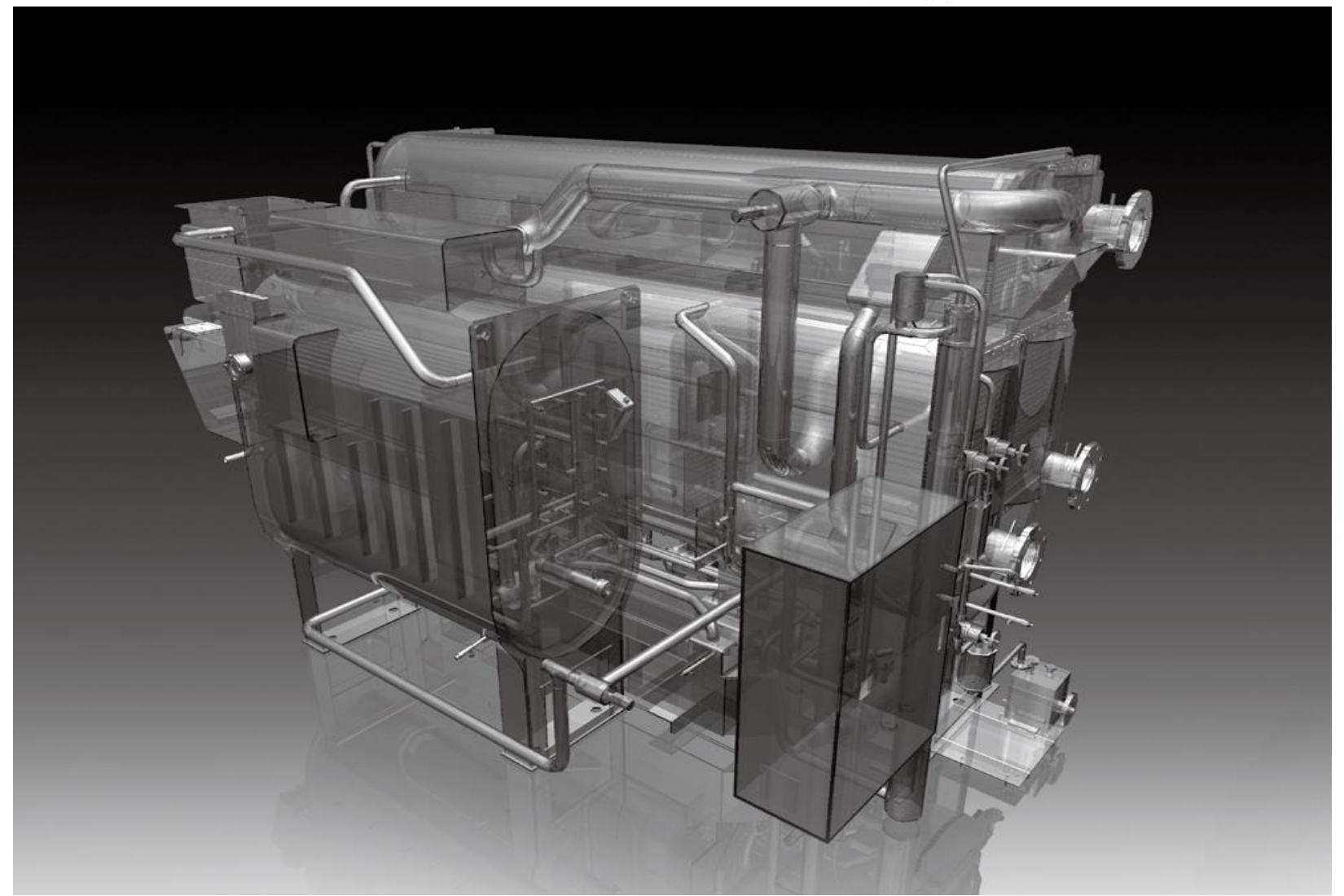

# MMC HVAC SOLUTION

## DIRECT FIRED

### ABSORPTION CHILLER



#### CÔNG TY CỔ PHẦN MIMICO

Tòa nhà SCETPA, số 19A Cộng Hòa, Phường 12, Quận Tân Bình, Tp. Hồ Chí Minh

Tel : 028 6292 5250 / 024 3232 2639

Website : [www.mimico.com.vn](http://www.mimico.com.vn)

Email : [Info@mimico.com.vn](mailto:Info@mimico.com.vn)

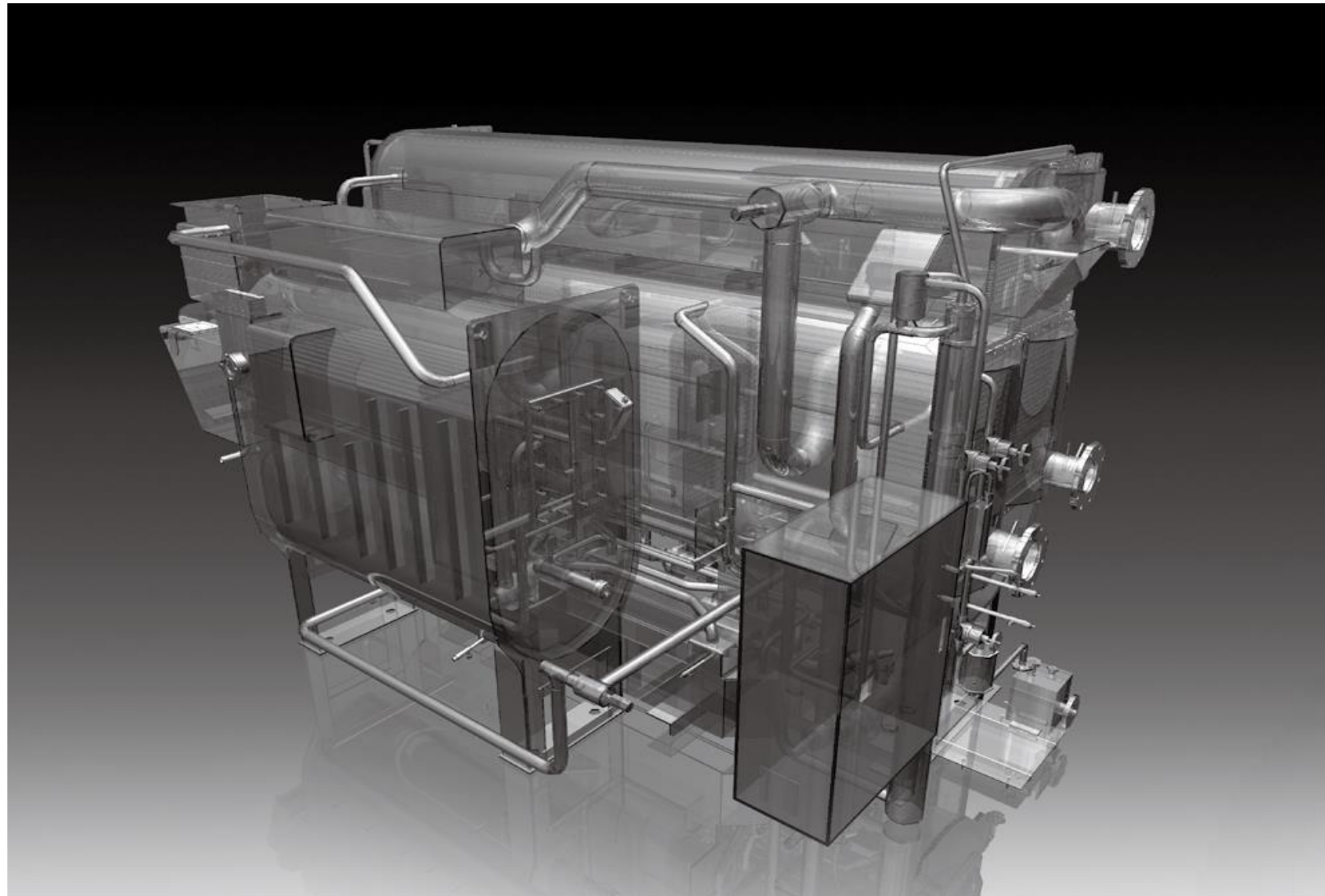

## Contents

Key Features .....	
Operating Principle.....	
Product Specification Table.....	
Foundation Schematic .....	
Delivery and Construction .....	
Combustion System.....	

# Key Features



## Key Features

- Microcomputer full-automatic control system with LG patent and powerful remote monitoring software;
- The most advanced control system —— PID, realizes high precision of temperature control in the range of  $\pm 0.1^{\circ}\text{C}$ , which can reduce the time reaching the rated refrigerating capacity and save energy sharply.
- The chiller can adjust the running status parameters automatically by the solution concentration monitor, which can be combined with the melting-crystal device to avoid crystallization.
- Self-cleaning refrigerate drop device is non-electricity and non-clog which can avoid the cooling capacity attenuation. The perpetual-use technology of solution guarantees much lower maintenance cost than other suppliers.
- The stepless adjustment of cooling capacity in the range of 10% to 100%.
- The imported key parts keep the chiller running steadily as long as 20 years. The compact-optimized structural design with smaller size and weight.
- Low requirements for installation: indoor, outdoor, rooftop, basement and so on.
- Stable performance, low noise, small vibration and even foundation bolt is unnecessary.
- Solution pump with automatic variable frequency adjustment conserves much more power in the partial load condition. Double-purging system by automatic injector makes purging convenient and thorough.
- The specialized imported burner with high burning efficiency and low pollution. Fuel selections including heavy oil, light oil, coal gas, natural gas and LPG.

## Model Label

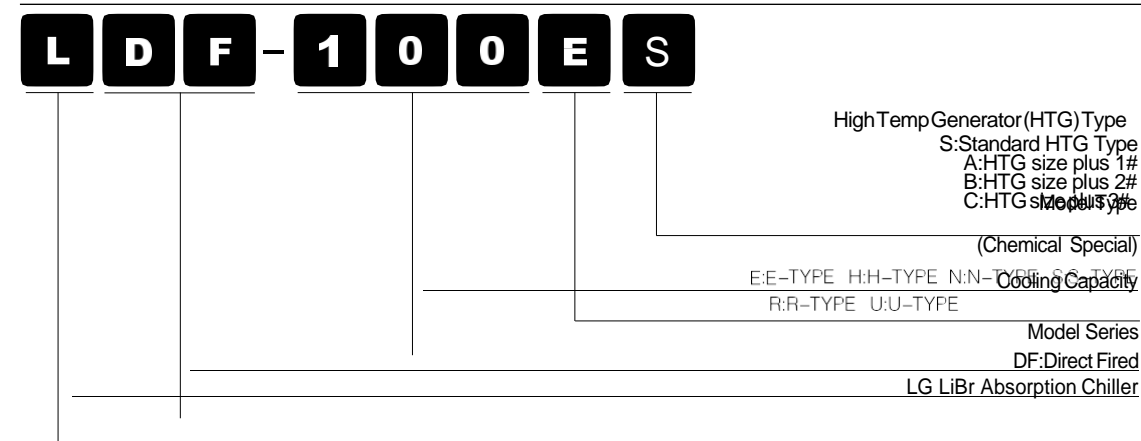

# principle of operation

## Operating Principle of Cooling

The body of chiller consists of the lower shell assembly, upper shell assembly, high temp generator (HTG), heat exchanger, solution pump, refrigerant pump and purging system. The lower shell assembly includes evaporator (EVAP) and absorber (ABSO); the upper shell assembly includes condenser (COND) and low temp generator (LTG).

When the chiller is running, the whole body is in a vacuum state. In EVAP, the low temp refrigerant from COND will absorb the heat of the chilled water from user, and at the same time, the refrigerant gets evaporated and turns to refrigerant steam. In ABSO, the strong solution will absorb the refrigerant steam from EVAP and turns to weak solution. The weak solution will be sent to HTG being heated after the heat exchanger. In HTG, the weak solution will turn to high temp middle solution after being heated by flame and exhaust gas and at the same time a great deal of high temp refrigerant steam emerges. The middle solution then will enter the LTG after heat exchange with the weak solution from ABSO, and then turn to strong solution after being heated by the high temp refrigerant steam from HTG. The strong solution then exchanges heat with the low temp weak solution from ABSO, and finally enters ABSO.

In the meantime, the refrigerant steam turns to high temp refrigerant liquid after releasing heat in LTG and enters COND combined with the new produced steam, finally both the steam and the liquid will be cooled and turn to low temp refrigerant liquid. The refrigerant liquid then returns EVAP after throttling and so a completed circulation is finished.

## Operating Principle of Heating

When the heating/cooling change-over valve is opening, refrigerant liquid and solution will be mixed. The mixture will be sent to HTG being heated and generates steam. The steam will heat the chilled water from the user and turn to liquid. Then the liquid will be mixed with the strong solution from HTG, and the mixture is sent to HTG again to complete the circulation.

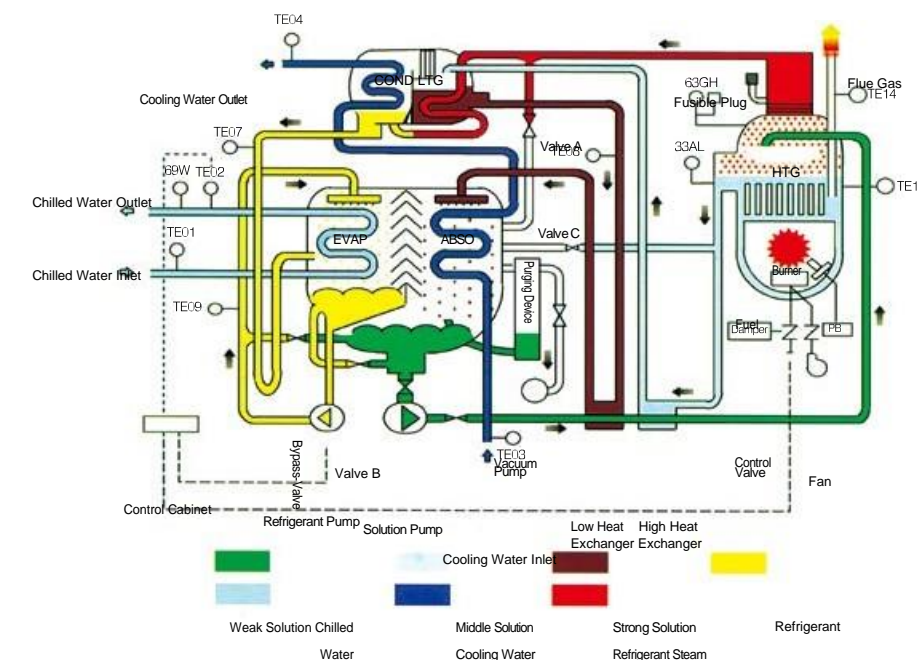

# product specification table

# product specification table

Model		UNIT	LDF-030ES	LDF-035ES	LDF-045ES	LDF-055ES	LDF-065ES	LDF-075ES	
Cooling Capacity	USRT		99	116	149	182	215	248	
	10 <sup>4</sup> Kcal/h		30	35	45	55	65	75	
	kW		349	407	523	640	756	872	
Heating Capacity	10 <sup>4</sup> Kcal/h		25	29	38	46	54	63	
Chilled Water Data	Temperature	°C	12→7						
	Water Flow rate	m <sup>3</sup> /h	60	70	90	110	130	150	
	Pressure Drop	mAq	6.5	6.6	8.0	8.3	7.5	7.9	
	Connection size	A	100			125			
Hot Water Data	Temperature	°C	55.8→60						
	Water Flow rate	m <sup>3</sup> /h	60	70	90	110	130	150	
	Pressure Drop	mAq	6.5	6.6	8.0	8.3	7.5	7.9	
	Connection size	A	100			125			
Cooling Water Data	Temperature	°C	32→37.5						
	Water Flow rate	m <sup>3</sup> /h	92.4	107.8	138.7	169.5	200.3	231.1	
	Pressure Drop	mAq	3.9	4.4	6.5	7.7	5.6	6.2	
	Connection size	A	125			150			
Power Supply	Voltage	V	3Φ380 50Hz						
	Total Current	A	11.8		13.7		14.7		
	Wire Size	mm <sup>2</sup>	4.0						
	Power Capacity	kVA	7.8		9.0		9.7		
Rated Power	NO.1 Absorbent Pump	kW(A)	2.5(6.8)						
	NO.2 Absorbent Pump	kW(A)	*****						
	Refrigerant Pump	kW(A)	0.2(1.3)						
	Purge Pump	kW(A)	0.4(1.1)						
	Air Blower	kW(A)	0.75(2.1)		1.5(4.0)		2.2(5.0)		
Dimension	Length	mm	2550	2750	3670		3690		
	Width	mm	2120		2280		2440		
	Height	mm	2050			2300			
Weight	Operating	ton	4.8	5.1	6.1	6.7	7.9	8.2	
	Total Shipping	ton	4.0	4.2	5.1	5.6	6.4	7.6	
	Transport Form	-	Whole Transport						
Fuel	GAS	Connection size	A 40						
		LNG(Cooling)	Nm <sup>3</sup> /h	20.8	24.3	31.2	38.2	45.1	52.0
		LNG(Heating)	Nm <sup>3</sup> /h	25.3	29.5	38.0	46.4	54.8	63.3
		City gas(Cooling)	Nm <sup>3</sup> /h	60.3	70.3	90.4	110.5	130.6	150.7
		City gas(Heating)	Nm <sup>3</sup> /h	73.2	85.4	109.9	134.3	158.7	183.1
	Oil	Connection size	A 15						
		Light oil(Cooling)	Kg/h	22.2	25.9	33.4	40.8	48.2	55.6
		Light oil(Heating)	Kg/h	27.0	31.5	40.5	49.5	58.5	67.5
Flue Connection Size	mm	280x210			310x310				
Clearance For Tube Removal	mm	2400			3400				

LDF-085ES	LDF-100ES	LDF-110ES	LDF-125ES	LDF-135ES	LDF-150ES
281	331	364	413	446	496
85	100	110	125	135	150
989	1163	1279	1454	1570	1745
71	84	92	105	113	125
12→7					
170	200	220	250	270	300
5.1	5.5	5.8	6.1	5.2	5.5
150			200		
55.8→60					
170	200	220	250	270	300
5.1	5.5	5.8	6.1	5.2	5.5
150			200		
32→37.5					
261.9	308.1	338.9	385.1	416.0	462.2
10.9	12.1	8.7	9.4	10.3	11.2
200			250		
3Φ380 50Hz					
21.5		23.7		31.7	
6.0			10.0		
14.2		15.6		20.9	
3.4 (9.1)					
1.3(4)		2.2(6.2)			
0.4(1.8)					
0.4(1.1)					
2.2(5.0)			5.5(13.0)		
4710		4810			
2440		2660		2900	
2300		2510		2800	
9.2	9.8	12.3	12.7	15.2	15.6
8.1	8.7	10.8	11.1	13.3	13.4
Whole Transport 40					
59.0	69.4	76.3	86.7	93.7	104.1
71.7	84.3	92.8	105.4	113.9	126.5
170.8	200.9	221.0	251.1	271.2	301.3
207.5	244.1	268.5	305.2	329.6	366.2
15					
63.0	74.1	81.5	92.6	100.1	111.2
76.6	90.1	99.1	112.6	121.6	135.1
310x310		360x310		410x310	
0		0		0	
4500					

NOTE: 1.1USRT=3024kcal/h=3.517kW, 1mAq=9.8KPa

2.Standard chilled water inlet/outlet TEMP is 12°C→7°C

3.Standard hot water inlet/outlet TEMP is 55.8°C→60°C

4.Standard cooling water inlet/outlet TEMP is 32°C→37.5°C

5. Standard chilled water, cooling water, hot water system: The highest pressure is 8kg/cm<sup>2</sup>G

6. Standard gas pressure: 900 ~ 1999 mmaq (Gas connection size is changed by the gas

pressure, gas value etc.) 7. Currents & Electricity Consumptions are based on 3Φ 380V 50Hz

8. Lower calorific value: LNG 11000kcal/Nm<sup>3</sup> City gas: 3800kcal/Nm<sup>3</sup> Light oil: 10300kcal/kg specific

gravity: 0.84 9. Total Shipping weight = REF. weight + SOLUTION weight + UNIT weight

10. The specifications are subject to change without prior notice

# product specification table

Model		UNIT	LDF-170ES	LDF-200ES	LDF-220ES	LDF-250ES	LDF-280ES	LDF-300ES	LDF-350ES	
Cooling Capacity	USRT		562	661	728	827	926	992	1157	
	10 <sup>4</sup> Kcal/h		170	200	220	250	280	300	350	
	kW		1977	2326	2559	2908	3256	3489	4071	
Heating Capacity	10 <sup>4</sup> Kcal/h		142	167	184	209	234	251	293	
Chilled Water Data	Temperature	°C	12→7							
	Water Flow rate	m <sup>3</sup> /h	340	400	440	500	560	600	700	
	Pressure Drop	mAq	4.6	6.2	8.1	4.7	6.4	8.4	6.2	
	Connection size	A	200			250			300	
Hot Water Data	Temperature	°C	55.8→60							
	Water Flow rate	m <sup>3</sup> /h	340	400	440	500	560	600	700	
	Pressure Drop	mAq	4.6	6.2	8.1	4.7	6.4	8.4	6.2	
	Connection size	A	200			250			300	
Cooling Water Data	Temperature	°C	32→37.5							
	Water Flow rate	m <sup>3</sup> /h	523.8	616.2	677.9	770.3	862.7	924.4	1078.4	
	Pressure Drop	mAq	7.1	9.4	12.1	8.4	11.1	14.3	8.8	
	Connection size	A	300			350			400	
Power Supply	Voltage	V	3Φ380 50Hz							
	Total Current	A	36.8	39.6		40.6	48.6	55.5	64.0	
	Wire Size	mm <sup>2</sup>	10.0			16.0		25.0		
	Power Capacity	kVA	24.2	26.1		26.7	32.0	36.5	42.1	
Rated Power	NO.1 Absorbent Pump	kW(A)	5.5(15.0)			7.5(23.0)				
	NO.2 Absorbent Pump	kW(A)	1.8(5.4)			1.8(6.4)		3.7(12.0)		
	Refrigerant Pump	kW(A)	0.4(1.8)						1.1(3.9)	
	Purge Pump	kW(A)	0.4(1.1)						0.75(1.9)	
	Air Blower	kW(A)	5.5(13.0)	7.5(15.8)			11.0(22.7)			
Dimension	Length	mm	4940	5480	5980	5620	6150	6700	6200	
	Width	mm	3300			3600			4150	
	Height	mm	3300			3730				
Weight	Operating	ton	21.8	23.5	25.3	33.5	36.1	38.9	44.3	
	Total Shipping	ton	19.1	20.6	22.1	29.4	31.8	34.3	39.8	
	Transport Form	-	Whole Transport			Fission Transport				
Fuel	GA S	Connection size	A	50	65			80		
		LNG(Cooling)	Nm <sup>3</sup> /h	118.0	138.8	152.7	173.5	194.3	208.2	242.9
		LNG(Heating)	Nm <sup>3</sup> /h	142.1	167.2	183.9	209.0	234.0	250.8	292.6
		City gas(Cooling)	Nm <sup>3</sup> /h	341.5	401.8	441.9	502.2	562.5	602.7	703.1
	City gas(Heating)	Nm <sup>3</sup> /h	412.1	482.6	531.4	603.9	676.3	724.6	845.4	
	Oil	Connection size	A	20						
		Light oil(Cooling)	Kg/h	126.0	148.2	163.0	185.3	207.5	222.3	259.4
		Light oil(Heating)	Kg/h	151.8	178.5	196.4	223.2	250.0	267.8	312.4
Flue Connection Size		mm	500×350			620×400			900×400	
Clearance For Tube Removal	mm	4600	5200	5700	5200	5700	6200	5700		

- NOTE:** 1.1USRT=3024kcal/h=3.517kW, 1mAq=9.8KPa 。  
 2.Standard chilled water inlet/outlet TEMP is 12°C→7°C  
 3.Standard hot water inlet/outlet TEMP is 55.8°C→60°C  
 4.Standard cooling water inlet/outlet TEMP is 32°C→37.5°C  
 5. Standard chilled water,cooling water.hot water system:The highest pressure is 8kg/cm<sup>2</sup>G

# product specification table

LDF-370ES	LDF-400ES	LDF-425ES	LDF-460ES	LDF-500ES	LDF-600ES	LDF-800ES	LDF-1000ES
1224	1323	1405	1521	1653	1984	2646	3307
370	400	425	460	500	600	800	1000
4303	4652	4943	5350	5815	6978	9304	11630
310	335	356	385	420	504	672	840
12→7							
740	800	850	920	1000	1200	1600	2000
7.9	9.8	8.0	9.8	14.1	21.2	14.5	22.4
300		350			400	500	
55.8→60							
740	800	850	920	1000	1200	1600	2000
7.9	9.8	8.0	9.8	14.1	21.2	14.5	22.4
300		350			400	500	
32→37.5							
1140.0	1232.5	1309.5	1417.3	1540.6	1848.7	2465.0	3081.2
10.9	13.4	12.3	14.6	12.2	19.8	15.0	28.4
400				400	500	600	
3Φ380 50Hz							
64.0	72.3		93.8		122.6	183.6	199.4
25.0	25.0			35.0	70.0	95.0	120.0
42.1	47.6			61.7	80.7	120.8	131.2
7.5(23.0)				17(42)	22(51)	17(42)×2	17(42)×2
3.7(12.0)					5.5(16.4)	7.5(27.8)	15(39)
1.1(3.9)				1.8(6.4)	2.2(7.4)	3.7(12)	
0.75(1.9)							
11.0(22.7)	15.0(31.0)				11.0(22.7)×2	15.0(31.0)×2	
6700	7200	6800	7400	8350	11000	12000	12750
4150		4560		4750	4500	5550	5700
3730		3930			3980	5230	
47.6	50.6	55.5	58.5	64.4	69.7	100.8	122.1
42.8	45.5	50.0	52.6	58.4	63.5	88.5	108.5
Fission Transport							
80				100	80×2		100×2
256.8	277.6	294.9	319.2	347.0	416.4	555.2	694.0
309.3	334.4	355.3	384.5	421.6	505.8	674.4	843.0
743.3	803.5	853.8	924.1	1004.4	1205.4	1607.0	2008.8
893.7	966.2	1026.6	1111.1	1220.5	1464.6	1952.8	2441.0
25							
274.2	296.5	315.0	340.9	370.6	444.6	593.0	741.2
330.3	357.1	379.4	410.6	450.5	540.2	720.2	901.0
900×400					620×400(2)	900×400(2)	
6200	6700	6200	6700	7900	8900	8200	10000

6. Standard gas pressure: 900 ~ 1999 mmaq(Gas connection size is changed by the gas pressure, gas value etc.)  
 7. Currents & Electricity Consumptions are based on 3Φ 380V 50Hz  
 8. Lower calorific value: LNG 11000kcal/Nm<sup>3</sup> City gas: 3800kcal/Nm<sup>3</sup> Light oil: 10300kcal/kg specific gravity: 0.84 9. Total Shipping weight = REF.weight + SOLUTION weight + UNIT weight  
 10. The specifications are subject to change without prior notice

# Foundation schematic

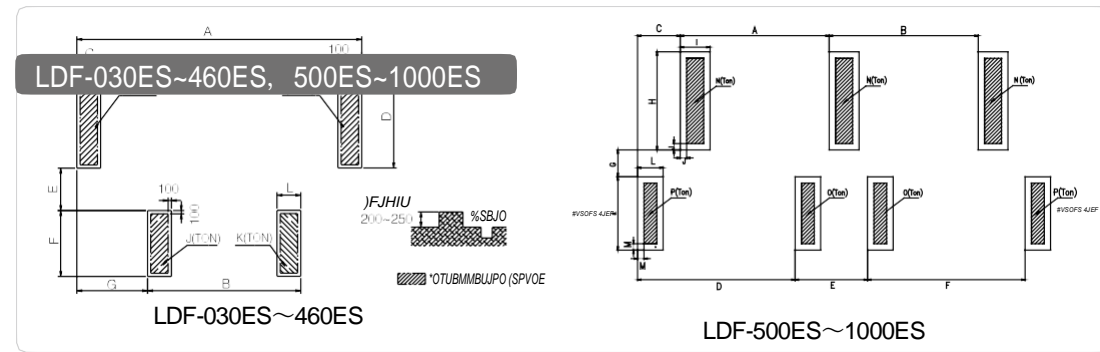

- NOTE:**
1. Please dig the drain around the chiller.
  2. In order to protect the chiller, the ground should be waterproof.
  3. The surface of the foundation should be level. (Levelness within 2/1000)

## Foundation Dimension

Model	A	B	C	D	E	F	G	H	I	J	K	L	M	N	O	P
LDF-030ES	2266	1220	340	880	150	640	425	1.6	1.6	0.7	0.9	330	/	/	/	/
LDF-035ES	2266	1420	340	880	150	640	425	1.7	1.7	0.8	0.9	330	/	/	/	/
LDF-045ES	3286	1470	340	880	178	750	657	2.1	2.1	0.9	1.0	330	/	/	/	/
LDF-055ES	3286	1670	340	880	178	750	657	2.3	2.3	1.0	1.1	330	/	/	/	/
LDF-065ES	3286	1720	360	940	245	750	668	2.8	2.8	1.1	1.4	370	/	/	/	/
LDF-075ES	3286	1920	360	940	245	750	500	2.8	2.8	1.2	1.4	370	/	/	/	/
LDF-085ES	4306	2220	360	940	190	750	1102	3.3	3.3	1.2	1.4	370	/	/	/	/
LDF-100ES	4306	2420	360	940	211	750	897	3.5	3.5	1.3	1.5	370	/	/	/	/
LDF-110ES	4306	2170	420	980	333	820	1115	4.4	4.4	1.7	1.8	420	/	/	/	/
LDF-125ES	4306	2370	420	980	333	820	1115	4.5	4.5	1.8	1.9	420	/	/	/	/
LDF-135ES	4306	2470	420	1080	336	920	830	5.4	5.4	2.1	2.3	420	/	/	/	/
LDF-150ES	4306	2670	420	1080	336	920	830	5.5	5.5	2.2	2.4	420	/	/	/	/
LDF-170ES	4306	2400	470	1280	250	1320	1120	8.0	8.0	2.7	3.1	400	/	/	/	/
LDF-200ES	4848	2650	470	1280	230	1320	1120	8.6	8.6	3.0	3.3	400	/	/	/	/
LDF-220ES	5346	2850	470	1280	250	1320	1120	9.2	9.2	3.3	3.6	400	/	/	/	/
LDF-250ES	4848	2900	520	1480	210	1520	1200	12.4	12.4	4.1	4.6	500	/	/	/	/
LDF-280ES	5346	3200	520	1480	210	1520	1200	13.2	13.2	4.6	5.1	500	/	/	/	/
LDF-300ES	5871	3500	520	1480	210	1520	1200	14.1	14.1	5.2	5.5	500	/	/	/	/
LDF-350ES	4946	3600	520	1600	390	1620	10	15.6	15.6	6.4	6.7	500	/	/	/	/
LDF-370ES	5471	3900	520	1600	390	1620	10	16.7	16.7	6.9	7.3	500	/	/	/	/
LDF-400ES	5971	4200	520	1600	390	1620	10	17.6	17.6	7.5	7.9	500	/	/	/	/
LDF-425ES	5471	4200	520	1820	590	1700	287	19.3	19.3	8.3	8.6	500	/	/	/	/
LDF-460ES	5971	4400	520	1820	590	1700	0	20.4	20.4	8.7	9.0	500	/	/	/	/
LDF-500ES	5100	1366	10	4100	-	-	440	1820	520	100	1700	500	100	14.5	11.2	10.9
LDF-600ES	3740	3741	104	3000	1710	3000	510	1820	520	100	1520	500	150	16.1	5.2	5.5
LDF-800ES	3498	3498	1002	3700	1700	3700	630	2300	700	150	1720	600	150	23.4	7.5	7.9
LDF-1000ES	4430	4430	270	4100	1300	4100	590	2300	700	150	1800	600	150	26.0	10.9	11.2

Note : LDF-500ES consists of 3 bases for body and 2 bases for HTG

# Delivery and construction

Contents		Delivery and Construction	
Chiller	Absorption Chiller	○	Refer to the second introduction
Transportation and Installation	Packing and Delivery	○	Deliver by truck
	Construction Site Removal	○	
	Installation	△	Chiller Levelness Adjustment
	Unit Commissioning	△	Once for Cooling and Once for Heating
Electric Engineering	Operating Instruction	△	Once
	Exterior Wiring	○	Please connect the wire to the control cabinet
Other Engineering	Foundation Engineering	○	
	Exterior Pipe Connection	○	
	Prevention of Pipe Freeze	○	Especially in winter, take measures to prevent freeze in pipe
	Cooling Water Quality Management	○	Please install cleansing device
	Insulation for Heating	○	
	Insulation for Cooling	○	
Paint	First Coat of Chiller Body	○	
	Control Cabinet Paint	○	
Others	LiBr Solution		

1. Please supply necessary materials for installation and test for free like water, electricity, mortar, fuel and so on.

2. Absorption Chiller

- a) Including EVAP, ABSO, HTG, LTG, COND, heat exchanger and pump.
- b) Purge Device
- c) Burner, Air Blower, Burning Safety Device
- d) Capacity Control Device
- e) Safety Device
- f) Control Panel
- g) Absorption Solution and Refrigerant
- h) Interior Pipe and Wire Connection

3. Attachment

Operating Manual..... One Piece

△ If customer requires this item, the cost shall be calculated separately.

# burning system Diagram

## Gas-burning Type

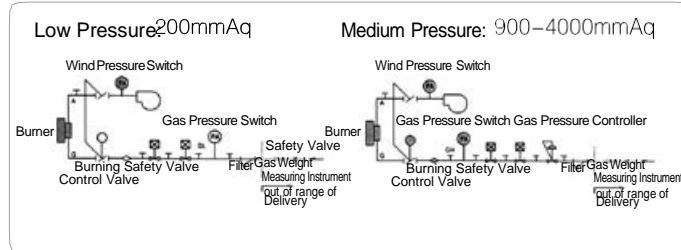

## Oil-burning Type

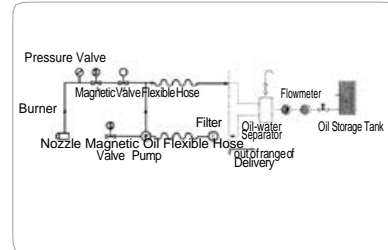

### Attention

1. The filter should be more than 80 meshes.
2. Please install aeration devices at the position where air is likely to be blocked.
3. Oil return tube for oil tank is necessary.
4. Valve installed on the oil return pipe is forbidden.

5. The oil level of tank should be 4m higher than the pump.  
The suction side pressure of the pump should be set between 0 and 0.35Kg/m<sup>2</sup>G. The height of oil return tube should be 5m below.
6. The flowmeter should be installed on the pipe of oil supply and return side.

## Key points for cooling water temperature control

The cooling water for MMC chiller should meet requirements as below in case of too low temperature. The cooling water temperature difference between user and design data should be within 13°C, for example, design data for cooling water temperature is 32°C, then the water temperature provided by user should be above 19°C.

1. Temperature control method: By the cooling tower
2. Cooling tower fan control by frequency conversion

## Management method for the cooling water quality

The cooling water will be concentrated after evaporating in the cooling tower, and then the quality turns bad. The low quality of the cooling water will cause erosion and fouling, so please install the cleansing device. Besides, the cooling water quality may be much better if treatment chemical is added. Please refer to the right side table: the water quality standard for general air conditioners.

## Management standard for the cooling water quality

Item	Standard Value	Trend	
		Erosion	Fouling
PH(25°C)	6.5-8.0	○	○
Electrical Conductivity (25°C)(us/cm)	< 800	○	○
Cl <sup>-</sup> (mg/l)	< 200	○	
SO <sub>4</sub> <sup>2-</sup> (mg/l)	< 200	○	
Acid Consumption (PH4.8)(mg/l)	< 100		
Hardness(mg/l)	< 200		
Fe(mg/l)	< 1.0	○	○
S <sup>2-</sup> (mg/l)	Undetected	○	
NH <sub>4</sub> <sup>+</sup> (mg/l)	< 1.0	○	
SiO <sub>2</sub> (mg/l)	< 50	○	

## Make-up water quality standard (reference value)

Item	Standard Value
PH(25°C)	6.5-8.0
Electrical Conductivity (25°C)(us/cm)	< 200
Cl <sup>-</sup> (mg/l)	< 50
SO <sub>4</sub> <sup>2-</sup> (mg/l)	< 50
Acid Consumption (PH4.8)(mg/l)	< 50
Hardness(mg/l)	< 50
Fe(mg/l)	< 0.3
S <sup>2-</sup> (mg/l)	Undetected
NH <sub>4</sub> <sup>+</sup> (mg/l)	< 0.2
SiO <sub>2</sub> (mg/l)	< 30